

DC Vibrator Manual



Installation, Manual & Maintenance

The Cleveland Vibrator Co. line of DC Electric Vibrators for Truck & Trailer Unloading applications feature a wide range of force outputs and construction types for handling tougher material flow challenges. Our DC Vibrators comes in forces from 80 lbf. all the way up to 3500 lbf., making this product line a perfect solution for handling any load size within your truck or trailer hopper, spreader or screener.

WHAT'S INSIDE

- Electrical Requirements
- Wiring Instructions
- Installation Procedures
- Mounting Locations
- Performance Data
- Troubleshooting



TABLE OF CONTENTS

Introduction	2
Installation	3-5
Proper Welding Tips	6
Wiring Diagram & Instructions	7-10
Performance Data	11
Maintenance Checks	11
Troubleshooting	12
Warranty	12

INTRODUCTION

Thank you for purchasing DC Electric Vibrators from the Cleveland Vibrator Company. Please review all installation, maintenance, operation, and model specific information carefully before use. If any assistance is required, do not hesitate to call our sales department with questions: **(800) 221-3298**



PRECAUTIONS

1. Read this entire manual and follow all installation and operating instructions.
2. Always use a proper ground cable.
3. Always use a safety cable to attach the vibrator to an independent stronghold. Do not operate the vibrator on an empty structure. This can damage the structure or the vibrator.
4. If a truck battery is used to power the vibrator, the vehicle engine should remain running while the vibrator is in use. Keep all ancillary equipment such as air conditioners turned off while operating the vibrator.
5. Do not operate the vibrator with the cover removed or if any fasteners are missing.
6. Disconnect or lock out the electrical supply before performing maintenance on the vibrator.
7. Persons near the vibrator should wear ear protection if the decibel levels exceed 90 dB.

Installation



- Vibrators have a ~5 ft. radius of influence on material and structure
- Vibration transfers better through curves than through corners
- When in doubt where to place a vibrator, **think about where your problem point is** and make sure vibration gets to it
- Be aware of rigid structural elements

MOUNTING ON TRUCK BED

Mount each vibrator on an independent channel iron. Locate the channel iron as close as possible to the material flow problem area. The most common problem areas are in the corners of the dump body.

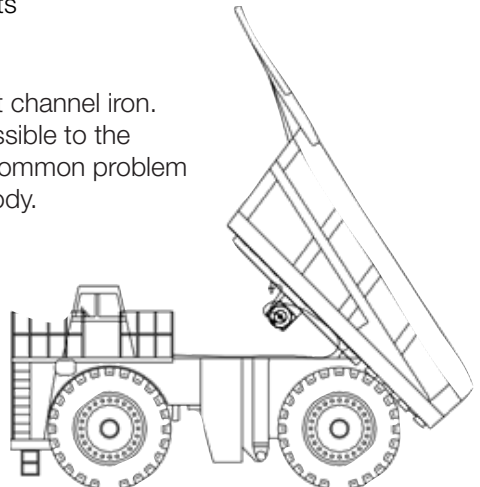

Installation



ORIENTATION OF VIBRATOR

The vibrator should be mounted with the shaft horizontal and the DC motor on the right when looking at the application from outside the structure with the direction of material flow from top to bottom. This will provide the proper direction of rotation to assist material flow.

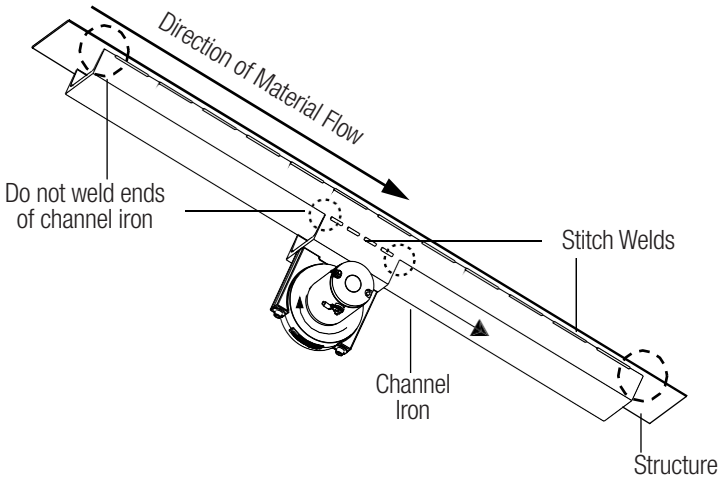

SINGLE VIBRATOR

Install a channel iron stiffener on the outside of the sloping wall $1/3$ the distance above the discharge opening.

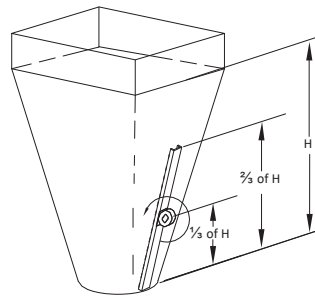

THREE VIBRATORS

Install channel iron stiffeners mounted 120° apart. Install the first vibrator on the outside of the sloping wall $1/4$ the distance above the discharge opening. Install the second vibrator on a separate channel iron at $1/2$ the distance above the discharge opening. Install the third vibrator on the remaining channel iron at $3/4$ the distance above the discharge opening.

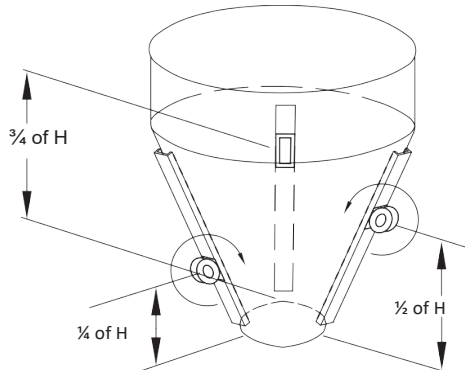

Installation

MULTIPLE VIBRATORS

Use more than one vibrator when the diameter or width of any wall is greater than 8 feet (3.66 m). Always mount the vibrators on different planes.

Small Hopper
Hopper Diameter
<8 ft.
1 Unit



Medium Hopper
Hopper Diameter
8-15 ft.
2 Units
180° Apart



Large Hopper
Hopper Diameter
>15 ft.
3 Units
120° Apart

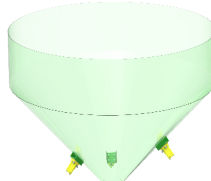

TWO VIBRATORS ON ROUND OR SQUARE HOPPERS

Install channel iron stiffeners 180° apart. Install one vibrator on the outside of the sloping wall 1/3 the distance above the discharge opening. Install the second vibrator on the outside of the opposite sloping wall 2/3 the distance above the discharge opening.

TWO VIBRATORS ON RECTANGULAR HOPPERS

Install channel iron stiffeners on opposite sides of the long walls. Install one vibrator on the outside of the sloping wall 1/3 the distance from the discharge opening. Install the second vibrator on the outside of the opposite sloping wall 2/3 the distance above the discharge opening. When only one wall slopes, mount both stiffeners on it. Equally space the stiffeners on the wall. Place one vibrator 1/3 above the discharge opening on one channel iron and the other vibrator 2/3 above the bin's discharge opening on the second channel.

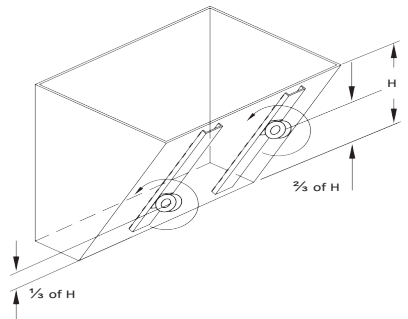
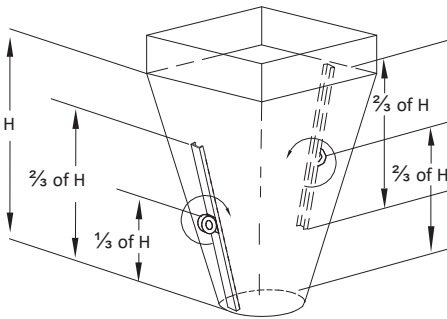

Proper Welding Techniques

- Never continuously weld
 - Leave the corners free of weld
 - The thickness of the weld should be at least as thick as the minimum thickness of either the bin wall or the mounting channel
- For example:** if welding our SMP-2 on a 1/4" thick bin wall, use a weld that is at least 1/4" thick
- It is the responsibility of the welder to know the thickness of the bead and the penetration of the weld into both the channel and the bin wall. Penetration is critical. Too deep, the weld will go through the bin wall. Too shallow, the mounting channel hopper joint will fail
 - It is suggested to have an equal 1:1 ratio of weld bead to gap between welds.
- For example:** if an SMP-2 is being installed, we suggest 2" beads then 2" gap then 2" bead then 2" gap, etc.

CAUTION!

Do not mount the vibrator directly to the structure wall. Use a channel iron stiffener for proper mount rigidity and as the transducer of the vibrational energy.

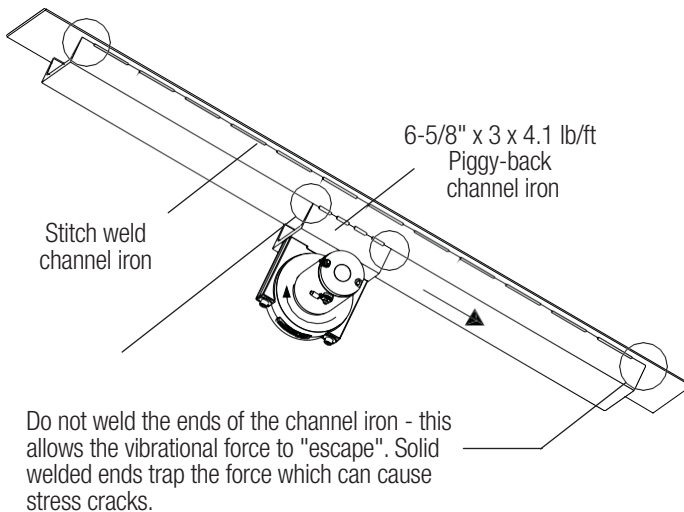

The key to successful vibration is a proper mount because rotary vibration resonates the material inside the structure, when the vibrator is mounted correctly. The vibrator should appear motionless. There should not be a large amount of motion or noise.

Wiring Instructions



Intended for Spreader Applications:

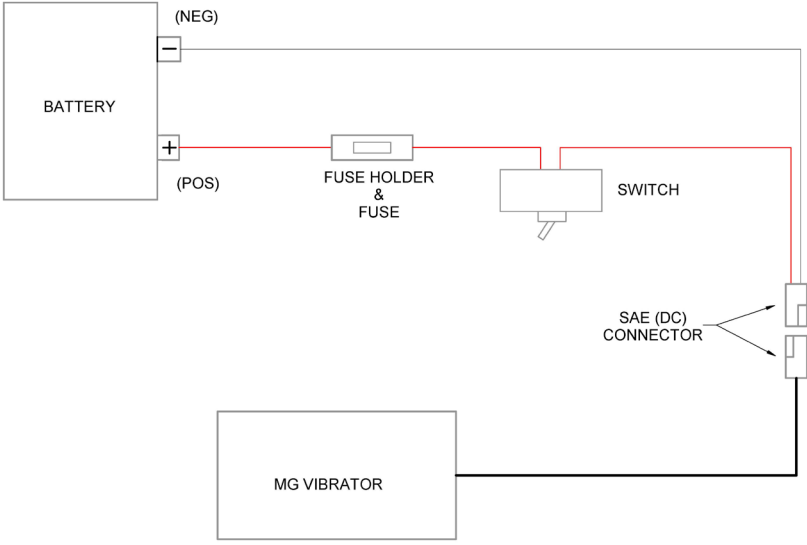

Wiring Instructions

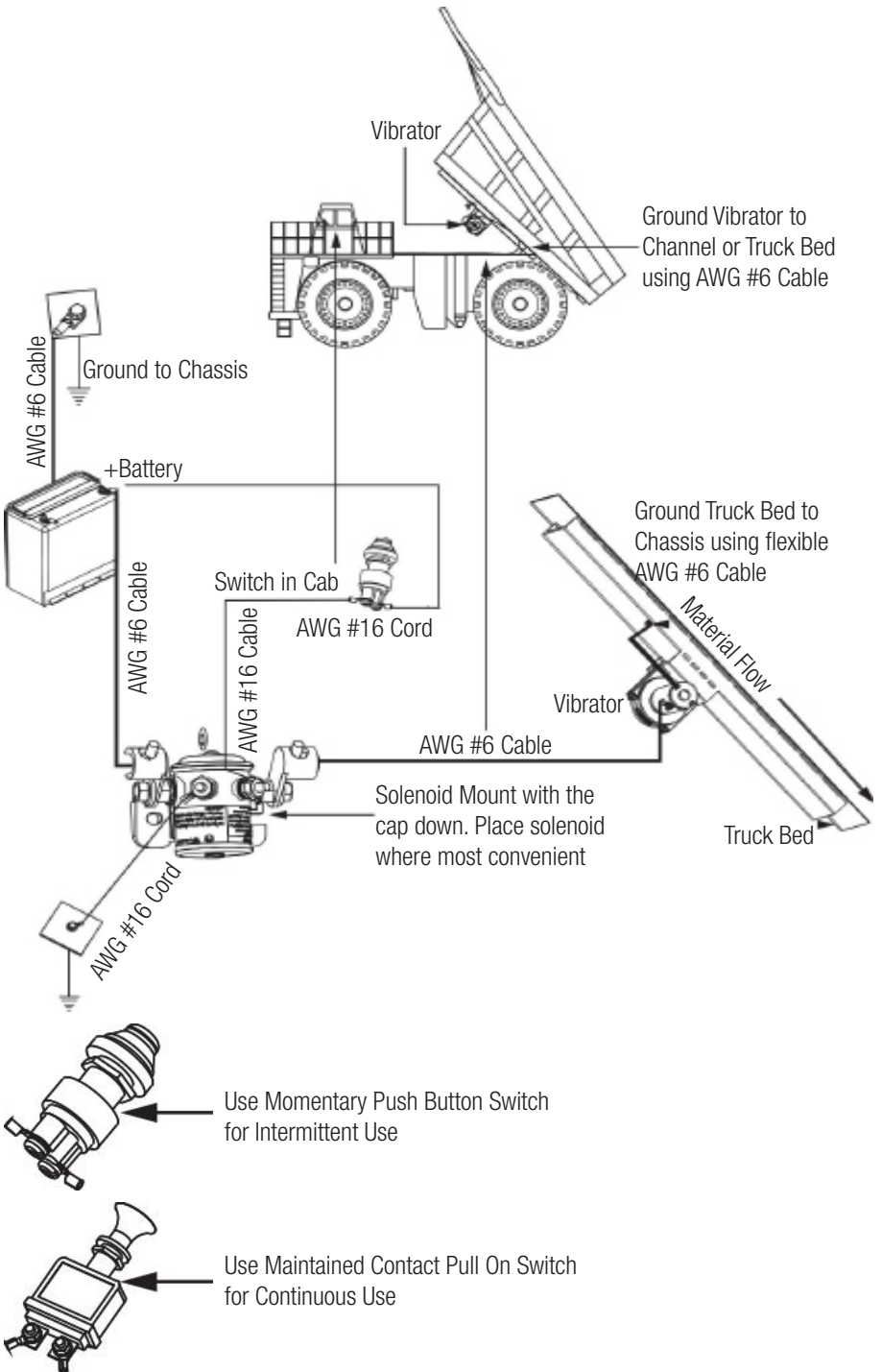

Wiring Instructions



To assist in the installation Cleveland Vibrator Company offers DC Electric Accessory Kits include:

- Push button switch (intermittent use) or pull on switch (continuous use)
- Solenoid (12V or 24V)
- 25 feet of AWG #6 cable with terminal and hardware to connect to the vibrator
- Terminal to connect the cable to the solenoid

See the drawing on page 6 which illustrates necessary connections.

OPERATING REQUIREMENTS

The MG 12V DC models require a 12 volt/25 amp DC power source and the MG 24V DC models require a 24 volt/12.5 amp DC power source. Refer to page 11 for maximum temperature ratings per product model.

TRUCK DUMP BODY APPLICATIONS

Continuous operation can run down the vehicle battery. Keep the vehicle engine running during vibrator use. Time for the vehicle alternator to recharge the battery between vibrator ON cycles might be required. Increasing the vehicle engine speed (rpm) might be necessary during vibrator operation if the vibrator draws more current than the vehicle's alternator can produce when the engine is idling. Do not operate the vehicle's air conditioner or other ancillary equipment while the vibrator is running.

CONTROLLING VIBRATOR SPEED

A rheostat can be used to control the speed of DC electric vibrators. Operating the vibrator at lower voltages will slow the speed of the vibrator, reduce the force of the vibrator, and enhance the bearing life (a 10% decrease in speed increases the bearing life by 50%). If using a rheostat to control the vibrator speed, reduce the speed using the rheostat until material flow stops. Gradually increase the voltage until the speed of the vibrator is adequate to maintain the material flow.

Wiring Instructions



WIRING TO POWER SOURCE AND SWITCHING

1. Be sure all the equipment is all rated for the same voltage

12 Volt Battery	OR	24 Volt Battery
12 Volt Vibrator		24 Volt Vibrator
12 Volt Solenoid		24 Volt Solenoid

2. Be sure the negative battery terminal is properly grounded to the truck chassis.
3. Connect the positive battery terminal to the large input terminal on the solenoid using AWG #6 cable or heavier.
4. Ground the small input terminal on the solenoid to the truck chassis or the negative battery terminal using AWG #16 wire or heavier.
5. Connect the large output terminal of the solenoid to the power terminal on the vibrator using AWG #6 cable or heavier. The DC Electric Vibrator Accessory kits include the solenoid and 25 feet of cable with the necessary terminal and connectors to do this.
6. Connect the appropriate switch to the small output terminal on the solenoid using AWG #16 wire or heavier. Use a push button switch for intermittent use and a pull on switch for continuous use. The appropriate switch is included in the DC Electric Vibrator Accessory kits.
7. Connect the other side of the switch to the positive battery terminal using AWG #16 wire or heavier.
8. Connect the ground terminal found on the end cover of the vibrator motor to the mount channel or truck bed using AWG #6 cable or heavier.

CAUTION!

ALL wires and cables connecting to the vibrator should have some slack.

The vibrator must be properly grounded. A heavy duty ground cable or strap should be used to complete the electrical circuit between the truck bed and the truck frame to insure proper grounding and operation.

For non-truck applications, mount the solenoid & switch where most convenient.

Performance Data



12 & 24 VOLT DC VIBRATORS PERFORMANCE DATA						
Vibrator Model	Speed (RPM)	Force (lbs/kN)	Voltage (V)	Amp Draw	Duty Cycles	Temp Rating (F°)
MG-80	2900	100 lbs	12V DC	4	Continuous Duty	-25 F° to 125 F°
		0.36 kN				
MG-200	4400	300 lbs	12V DC	14	Continuous Duty	-25 F° to 100 F°
		0.89 kN				
MG-400-12	5400	455 lbs	12V DC	25	Continuous Duty	Up to 110 F°
		2.03 kN				
MG-800-12	5400	845 lbs	12V DC	25	Continuous Duty	Up to 110 F°
		3.76 kN				
MG-1200-12	5400	1193 lbs	12V DC	25	Continuous Duty	Up to 110 F°
		5.03 kN				
MG-400-24	5400	455 lbs	24V DC	13	Continuous Duty	Up to 110 F°
		2.03 kN				
MG-800-24	5400	845 lbs	24V DC	13	Continuous Duty	Up to 110 F°
		3.76 kN				
MG-1200-24	5400	1193 lbs	24V DC	13	Continuous Duty	Up to 110 F°
		5.03 kN				
MG-3500	4000	3500 lbs	12V DC	60	10 Minutes On 60 Minutes Off	-4 F° to 122 F°
		15.57 kN				

Force output is determined by the speed the motor rotates. Motor speed can be affected by the type and quality of the mount and the load on the motor. Follow manufacturer's guidelines for optimum performance.

Maintenance Checks



MAINTENANCE

The MG DC vibrators require very little maintenance. These vibrators are equipped with shielded bearings that are permanently lubricated at the factory. No lubrication is required. Periodically check for loosening of the mount.

Periodically check bolts and welds.

Troubleshooting

PROBLEM	PROBABLE CAUSE	SOLUTION
Vibrator will not operate	Poor electrical connections	Check to make sure all electrical connections, including ground connections, are secure and free of corrosion. Check switch to ensure it is making contact
	Field/Armature is locked up	Disconnect and check to make sure shaft turns freely
Vibrator starts but fails to continue to operate	Battery is low	Recharge battery. Keep engine running while operating vibrator. Turn off other accessories using battery
	Brushes are worn	Replace brushes in motor
	Short circuit in motor windings	Replace motor
Vibrator makes too much noise	Inadequate mount	Be sure all mounting bolts are tight and that mount is rigid and secure. Be sure all mounting instructions are followed
	Bearing failure (squealing noise)	Replace bearings
	Loose cover or motor	Be sure all bolts securing the cover and the motor to the vibrator housing are secure
Vibrator overheats	Inadequate mount	Be sure all mounting bolts are tight and that mount is rigid and secure. Be sure all mounting instructions are followed
	Ambient temperature is too hot for vibrator	Protect vibrator from ambient temperatures above 130°F (54°C)
	Vibrator has been operated continuously for too long	The MG vibrators are rated for continuous use when ambient temperatures are 110°F (43°C) or less. If temperatures exceed 110°F (43°C), the vibrator should not be run continuously for more than 30 minutes. Allow the vibrator to cool for at least one minute for each minute of continuous operation up to 30 minutes. Accessory kits for intermittent and continuous use are available from Cleveland Vibrator Company

Warranty

Cleveland Vibrator Company industrial vibrators are warranted for 6 months from the date of shipment, if the unit is installed and operated in accordance with the factory instructions. The warranty covers material defects and manufacturer's workmanship.

FOR MORE INFORMATION

Call: Sales at 800-221-3298

Email: sales@clevelandvibrator.com

Buy Online: www.clevelandvibrator.com

